



深圳市勋瑞光电科技有限公司

Xunrui Shenzhen Optoelectronics Technology Co., Ltd.



CERT. No. QAC0946535 (ISO9001) CERT. No. HKG002005 (ISO14001)

Product Specification

Customer: _____

Model Name: _____ H0144PQC23T1502 _____

Date: _____

Version: _____

Preliminary Specification

Final Specification

For Customer's Acceptance

| Approved by | Comment |
|-------------|---------|
| | |

| Approved by | Reviewed by | Prepared by |
|-------------|-------------|-------------|
| | | |



Contents

| | |
|--|----|
| 1.Record of Revision | 3 |
| 2 .General Specifications | 4 |
| 3 .Input/Output Terminals | 5 |
| 4. Absolute Maximum Ratings | 6 |
| 5 .Electrical Characteristics | 6 |
| 6 .Interface Timing | 7 |
| 7. Optical Characteristics | 9 |
| 8 . Environmental / Reliability Tests..... | 13 |
| 9. Mechanical Drawing | 14 |
| 1 0.Packing | 15 |
| 11. Precautions For Use of LCD modules | 16 |



1. Record of Revision

| Version | Revise Date | Content | Editor |
|---------|-------------|----------------|------------|
| 1.0 | 2016/06/12 | First Release. | Rich Liang |
| | | | |
| | | | |
| | | | |
| | | | |
| | | | |
| | | | |
| | | | |
| | | | |
| | | | |
| | | | |
| | | | |
| | | | |
| | | | |
| | | | |
| | | | |
| | | | |
| | | | |
| | | | |



深圳市勋瑞光电科技有限公司

Xunrui Shenzhen Optoelectronics Technology Co., Ltd.

2 General Specifications

| | Feature | Spec |
|-----------------|------------------------|-------------------------------|
| Characteristics | LCD Size | 1.44 inch |
| | Display Format | 128 (RGB) ×128 |
| | Interface | MCU |
| | Color Depth | 262 K |
| | Technology type | a-Si |
| | Display Spec. | 0.219(W)*0.219(H)um |
| | Display Mode | Normally White |
| | Driver IC | ST7735S |
| | Surface Treatment | HC |
| | Viewing Direction | 6 O'clock |
| | Gray Viewing Direction | 12 O'clock |
| Mechanical | LCM (W x H x D) (mm) | 29.00 (W) ×34.41 (H)×2.25(T) |
| | Active Area(mm) | 25.50(W) × 26.50(H) mm |
| | With /Without TSP | Without TSP |
| | Weight (g) | TBD |
| | LED Numbers | 2 LEDs |

Note 1: Viewing direction is following the data which measured by optics equipment.

Note 2: Requirements on Environmental Protection: RoHS

Note 3: LCM weight tolerance: +/- 5%



3 Input/Output Terminals

| NO. | SYMBOL | Description | I/O |
|-------|---------|-------------------------------|--------------|
| 1 | IOVCC | 1.8V/2.8V digital power | Power supply |
| 2 | GND | GND | Power supply |
| 3 | VCC | 2.8V digital power | Power supply |
| 4-11 | DB7-DB0 | DATE BUS | I/O |
| 12 | RD | Read signal | I |
| 13 | WR | Write signal | I |
| 14 | RS | Data/Commander selection | I |
| 15 | RESET | Reset | I |
| 16 | CS | Chip select | I |
| 17-18 | LEDK | LED backlight input (Cathode) | Power supply |
| 19 | LEDA | LED anode | Power supply |
| 20-21 | NC | NC | |
| 22 | GND | GND | Power supply |
| 23 | TE | TE | |



4 Absolute Maximum Ratings

| Item | Symbol | MIN | MAX | Unit | Remark |
|-----------------------|-----------|------|--------------|------|--------|
| Supply Voltage | V_{DD} | -0.3 | 3 | V | |
| Input Signal Voltage | V_{in} | -0.3 | $V_{DD}+0.3$ | V | |
| Logic Output Voltage | V_{OUT} | -0.3 | $V_{DD}+0.3$ | V | |
| Operating Temperature | T_{OPR} | -20 | 70 | °C | |
| Storage Temperature | T_{STG} | -30 | 80 | °C | |

5 Electrical Characteristics

5.1 Operating conditions:

| Parameter | Symbol | MIN | TYP | MAX | Unit | Remark |
|---------------------------|----------|-----|-----|-----|------|--------|
| Power Voltage | V_{CC} | 2.6 | 2.8 | 3 | V | |
| Digital Operation Current | I_{CC} | | | | mA | |

5.2 Driving Backlight

| Item | Symbol | MIN | TYP | MAX | Unit | Remark |
|-------------------|----------|-----|-----|-----|------|--------------------|
| LED current | I_F | - | 40 | 50 | mA | Note 1 Note 2,3 |
| Power Consumption | | | | | mW | |
| LED Voltage | V_F | | 3.2 | | V | |
| LED Life Time | W_{BL} | - | TBD | - | Hr | |

Note 1 : There are 1 Groups LED

Note 2 : $T_a = 25^{\circ}\text{C}$

Note 3 : Brightness to be decreased to 50% of the initial value



6 Interface Timing

6.1 AC Electrical Characteristics

| Parameter | Symbol | Condition | Specification | | | Unit | Related Pins |
|-----------------------------|---------|--------------------------|---------------|------|---------|------|--------------|
| | | | Min | Typ | Max | | |
| Power & Operation Voltage | | | | | | | |
| System Voltage | VDD | Operating Voltage | 2.5 | 2.75 | 4.8 | V | |
| Interface Operation Voltage | VDDI | I/O Supply Voltage | 1.65 | 1.8 | 3.7 | V | |
| Gate Driver High Voltage | VGH | | 11 | | 18 | V | Note 4 |
| Gate Driver Low Voltage | VGL | | -13 | | -7.5 | V | |
| Gate Driver Supply Voltage | | VGH-VGL | 18.5 | | 29 | V | Note 4 |
| Input / Output | | | | | | | |
| Logic-High Input Voltage | VIH | | 0.7VDDI | | VDDI | V | Note 1 |
| Logic-Low Input Voltage | VIL | | VSS | | 0.3VDDI | V | Note 1 |
| Logic-High Output Voltage | VOH | IOH = -1.0mA | 0.8VDDI | | VDDI | V | Note 1 |
| Logic-Low Output Voltage | VOL | IOL = +1.0mA | VSS | | 0.2VDDI | V | Note 1 |
| Logic-High Input Current | IIH | VIN = VDDI | | | 1 | μA | Note 1 |
| Logic-Low Input Current | IIL | VIN = VSS | -1 | | | μA | Note 1 |
| Input Leakage Current | IIL | IOH = -1.0mA | -0.1 | | +0.1 | μA | Note 1 |
| VCOM Voltage | | | | | | | |
| VCOM Amplitude | VCOM | | -2 | | -0.425 | V | |
| Source driver | | | | | | | |
| Source Output Range | Vsout | | 0.1 | | GVDD | V | |
| Gamma Reference Voltage | GVDD | | 3.15 | | 4.7 | V | |
| Source Output Settling Time | Tr | Below with 99% precision | | | 20 | us | Note 2 |
| Output Offset Voltage | Voffset | | | | 35 | mV | Note 3 |

Table 2 DC Characteristic



6.2 Timing chart

Parallel Interface Characteristics: 18, 16, 9 or 8-bit Bus (8080 Series MCU Interface)

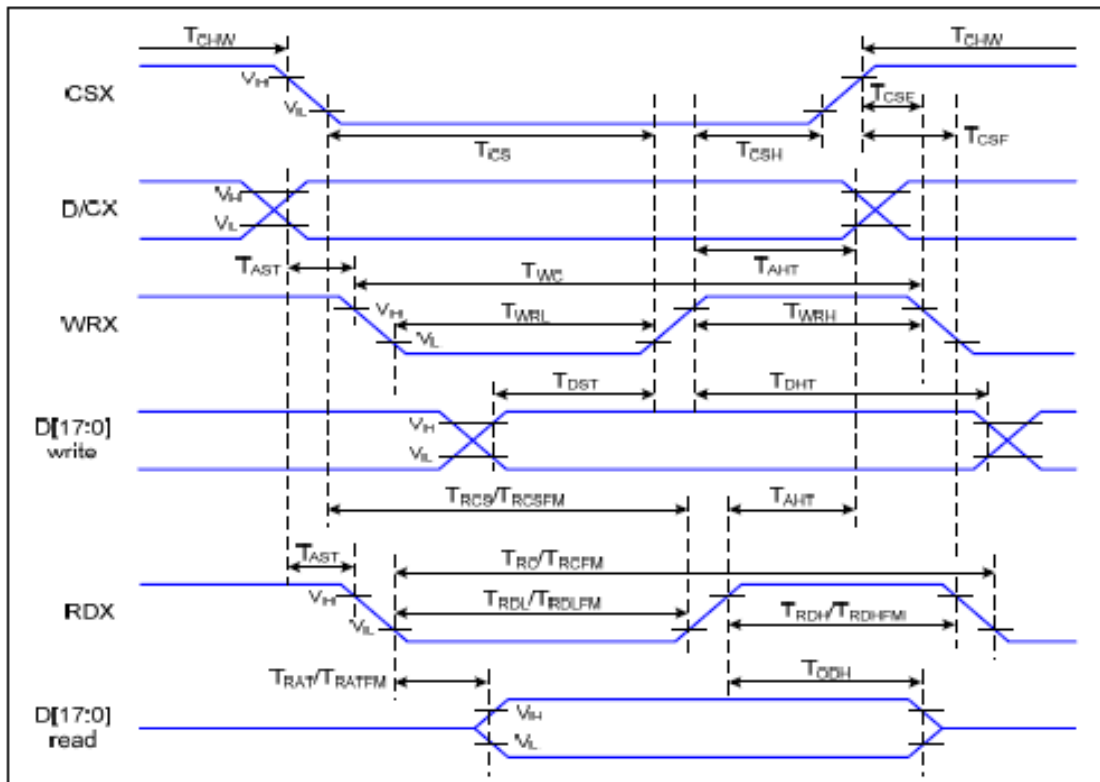

Ta=25 °C, VDDI=1.65~3.7V, VDD=2.5~4.8V

| Signal | Symbol | Parameter | Min | Max | Unit | Description |
|----------|--------|------------------------------------|-----|-----|------|-------------------|
| D/CX | TAST | Address Setup Time | 0 | | ns | - |
| | TAHT | Address Hold Time (Write/Read) | 10 | | ns | |
| CSX | TCHW | Chip Select "H" Pulse Width | 0 | | ns | - |
| | TCS | Chip Select Setup Time (Write) | 15 | | ns | |
| | TRCS | Chip Select Setup Time (Read ID) | 45 | | ns | |
| | TRCSFM | Chip Select Setup time (Read FM) | 355 | | ns | |
| | TCSF | Chip Select Wait Time (Write/Read) | 10 | | ns | |
| | TCSH | Chip Select Hold Time | 10 | | ns | |
| WRX | TWC | Write Cycle | 66 | | ns | - |
| | TWRH | Control Pulse "H" Duration | 15 | | ns | |
| | TWRL | Control Pulse "L" Duration | 15 | | ns | |
| RDX (ID) | TRC | Read Cycle (ID) | 160 | | ns | When Read ID Data |
| | TRDH | Control Pulse "H" Duration (ID) | 90 | | ns | |
| | TRDL | Control Pulse "L" Duration (ID) | 45 | | ns | |



深圳市勋瑞光电科技有限公司

Xunrui Shenzhen Optoelectronics Technology Co., Ltd.

| | | | | | | |
|-------------|--------|---------------------------------|-----|-----|----|--------------------------------|
| RDX (FM) | TRCFM | Read Cycle (FM) | 450 | | ns | When Read from Frame Memory |
| | TRDHFM | Control Pulse "H" Duration (FM) | 90 | | ns | |
| | TRDLFM | Control Pulse "L" Duration (FM) | 355 | | ns | |
| D[17:0] | TDST | Data Setup Time | 10 | | ns | For CL=30pF |
| | TDHT | Data Hold Time | 10 | | ns | |
| | TRAT | Read Access Time (ID) | | 40 | ns | |
| | TRATFM | Read Access Time (FM) | | 340 | ns | |
| | TODH | Output Disable Time | 20 | 80 | ns | |

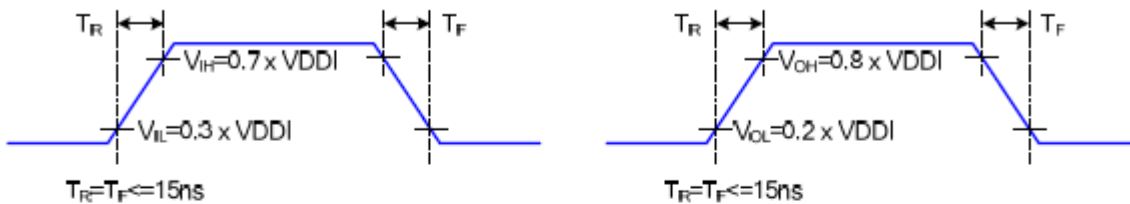

Figure 2 Rising And Falling Timing for Input And Output Signal

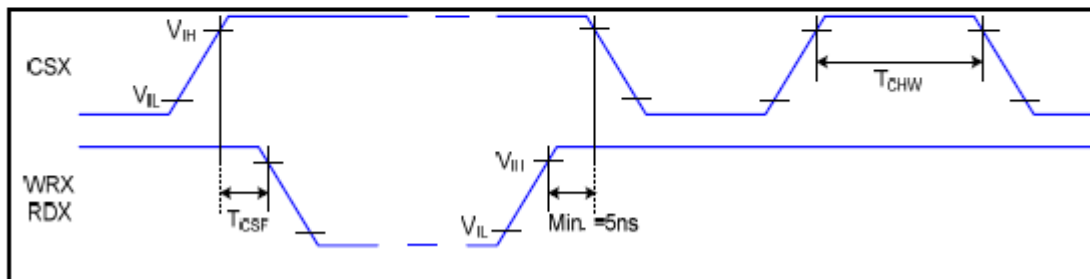

Figure 3 Chip Selection (CSX) Timing

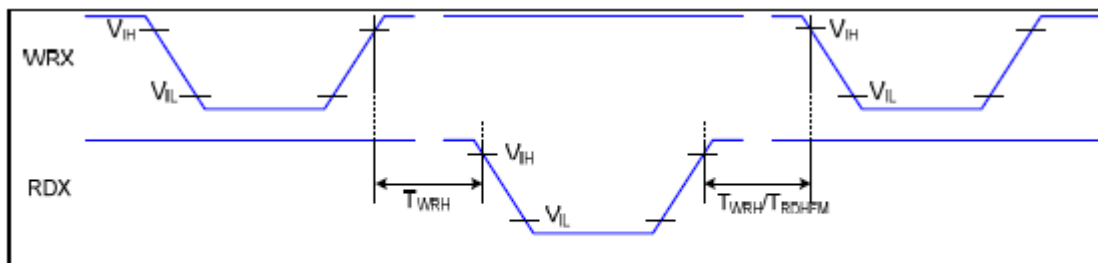

Figure 4 Write-to-Read And Read-to-Write Timing



7 Optical Characteristics

| Items | Symbol | Condition | Min. | Typ. | Max. | Unit | Remark | |
|----------------|------------|------------------------|-------|-------|-------|---------|-----------------|-----------------|
| Viewing angles | θ_T | Center CR \geq 10 | | 55 | - | Degree. | Note2 | |
| | θ_B | | | 45 | - | | | |
| | θ_L | | | 55 | - | | | |
| | θ_R | | | 55 | - | | | |
| Contrast Ratio | CR | $\Theta = 0$ | - | 350 | - | - | Note1, Note3 | |
| Response Time | T_{ON} | 25°C | - | 20 | 35 | ms | Note1, Note4 | |
| | T_{OFF} | | - | 25 | 40 | | | |
| Chromaticity | White | Backlight is on | X_W | 0.282 | 0.312 | 0.342 | - | Note1, Note5 |
| | | | Y_W | 0.319 | 0.349 | 0.379 | - | |
| | Red | | X_R | 0.609 | 0.639 | 0.669 | - | |
| | | | Y_R | 0.314 | 0.344 | 0.374 | - | |
| | Green | | X_G | 0.264 | 0.294 | 0.324 | - | |
| | | | Y_G | 0.557 | 0.587 | 0.617 | - | |
| | Blue | | X_B | 0.102 | 0.132 | 0.162 | - | |
| | | | Y_B | 0.106 | 0.136 | 0.166 | - | |
| Uniformity | U | | 80 | - | - | % | Note1, Note6 | |
| NTSC | | | | 50 | | % | Note5 | |
| Luminance | L | | 100 | 150 | | | Note1, Note7 | |

Test Conditions:

1. IF= 20mA(one channel),the ambient temperature is 25°C.
2. The test systems refer to Note 1 and Note 2.

Note 1: Definition of optical measurement system.

The optical characteristics should be measured in dark room. After 5 minutes operation, the optical Properties are measured at the center point of the LCD screen. All input terminals LCD panel must be ground when measuring the center area of the panel.



深圳市勋瑞光电科技有限公司

Xunrui Shenzhen Optoelectronics Technology Co., Ltd.

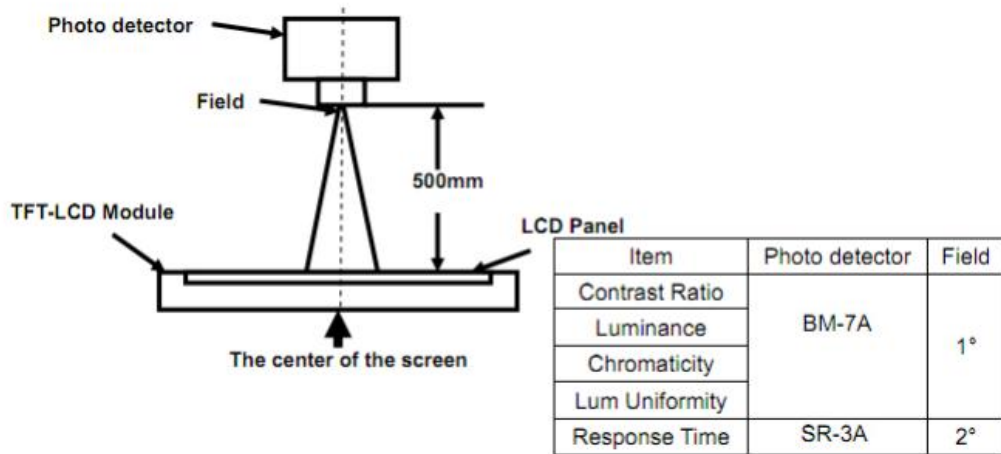

Note 2: Definition of viewing angle range and measurement system.
Viewing angle is measured at the center point of the LCD by CONOSCOPE (ergo-80).

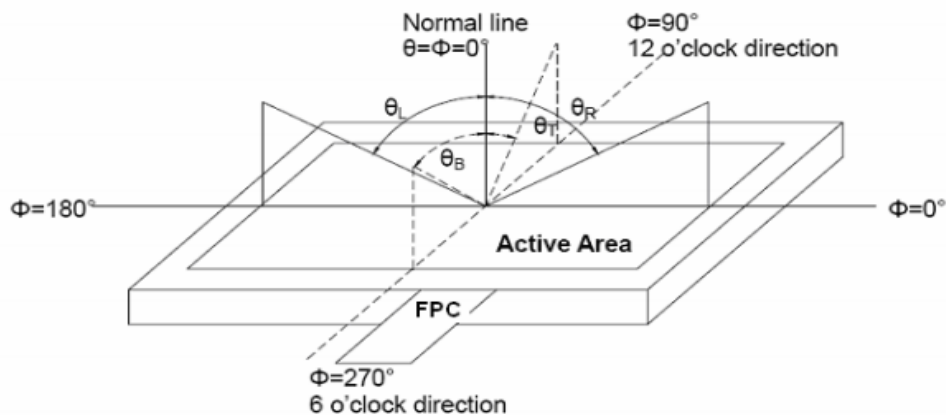

Fig. 1 Definition of viewing angle

Note 3: Definition of contrast ratio

$$\text{Contrast ratio (CR)} = \frac{\text{Luminance measured when LCD is on the "White" state}}{\text{Luminance measured when LCD is on the "Black" state}}$$

Note 4: Definition of Response time

The response time is defined as the LCD optical switching time interval Between "White" state and "Black" state. Rise time (TON) is the time between Photo detector output intensity changed from 90% to 10%. And fall time (TOFF) is The time between photo detector output intensity changed from 10% to 90%

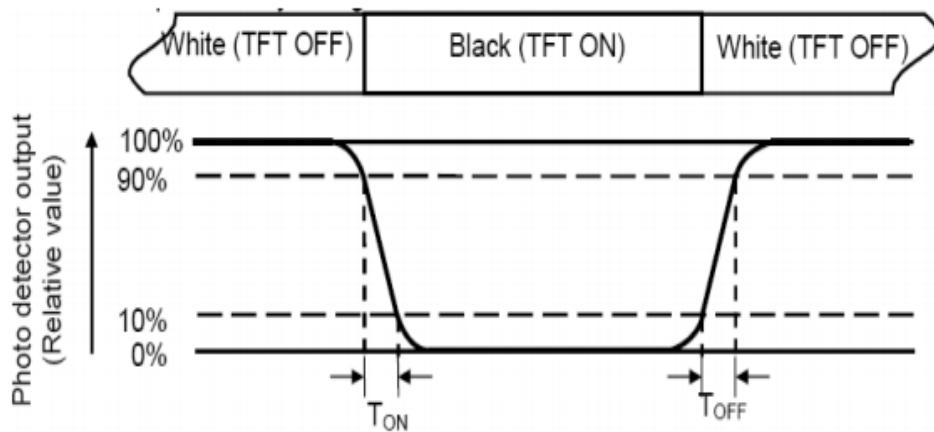

Note 5: Definition of color chromaticity (CIE1931)
Color coordinates measured at center point of LCD.

Note 6: Definition of Luminance Uniformity
Active area is divided into 9 measuring areas (Refer Fig. 2). Every measuring point is placed at the Center of each measuring area
Luminance Uniformity (U) = $L_{min} / L_{max} \times 100\%$
L-----Active area length W----- Active area width

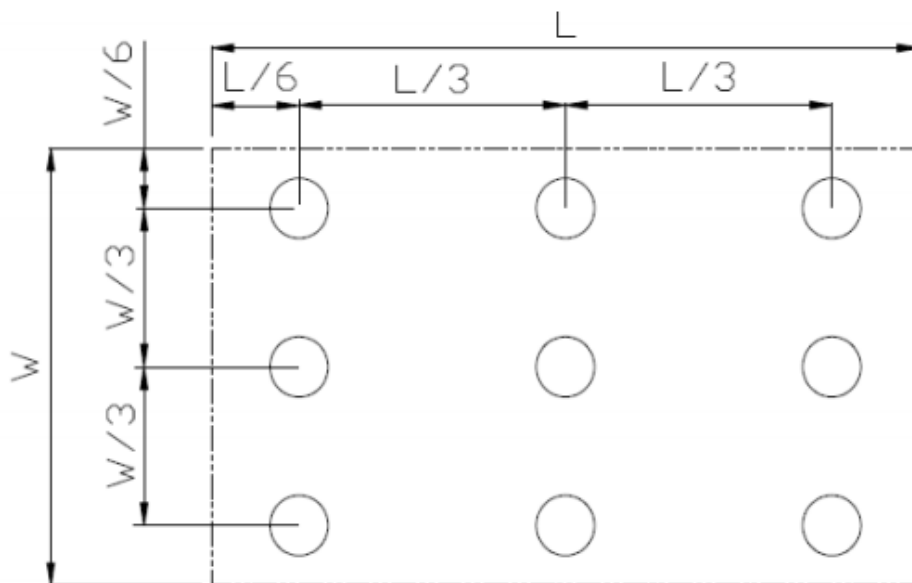

Fig. 2 Definition of uniformity

L_{max} : The measured maximum luminance of all measurement position.
 L_{min} : The measured minimum luminance of all measurement position.

Note 7: Definition of Luminance:
Measure the luminance of white state at center point.



8 Environmental / Reliability Tests

| No | Test Item | Condition | Remarks |
|----|--------------------------------------|--|--|
| 1 | High Temperature Operation | T _s = +70°C, 240hrs | Note 1 IEC60068-2-2, GB2423. 2-89 |
| 2 | Low Temperature Operation | T _a = -20°C, 240hrs | Note 2 IEC60068-2-1 GB2423.1-89 |
| 3 | High Temperature Storage | T _a = +80°C, 240hrs | IEC60068-2-2 GB2423. 2-89 |
| 4 | Low Temperature Storage | T _a = -30°C, 240hrs | IEC60068-2-1 GB/T2423.1-89 |
| 5 | High Temperature & Humidity Storage | T _a = +60°C, 90% RH max, 160 hours | IEC60068-2-3 GB/T2423.3-2006 |
| 6 | Thermal Shock (Non-operation) | -30°C 30 min ~ +80°C 30 min Change time: 5min, 30 Cycle | Start with cold temperature, end with high temperature IEC60068-2-14, GB2423.22-87 |
| 7 | Electro Static Discharge (Operation) | C=150pF, R=330 Ω, 5 points/panel Air:±8KV, 5 times; Contact: ±4KV, 5 times; (Environment: 15°C ~ 35°C, 30% ~ 60%, 86Kpa ~ 106Kpa) | IEC61000-4-2 GB/T17626.2-1998 |
| 8 | Vibration (Non-operation) | Frequency range: 10~55Hz, Stroke: 1.mm Sweep: 10Hz~55Hz~10Hz 2 hours for each direction of X .Y. Z. (package condition) | IEC60068-2-6 GB/T2423.5-1995 |
| 9 | Shock (Non-operation) | 60G 6ms, ± X, ±Y , ± Z 3 times for each direction | IEC60068-2-27 GB/T2423.5-1995 |
| 10 | Package Drop Test | Height: 60 cm, 1 corner, 3 edges, 6 surfaces | IEC60068-2-32 GB/T2423.8-1995 |

Note: 1. T_S is the temperature of panel's surface.

2. T_a is the ambient temperature of sample.



9 Mechanical Drawing

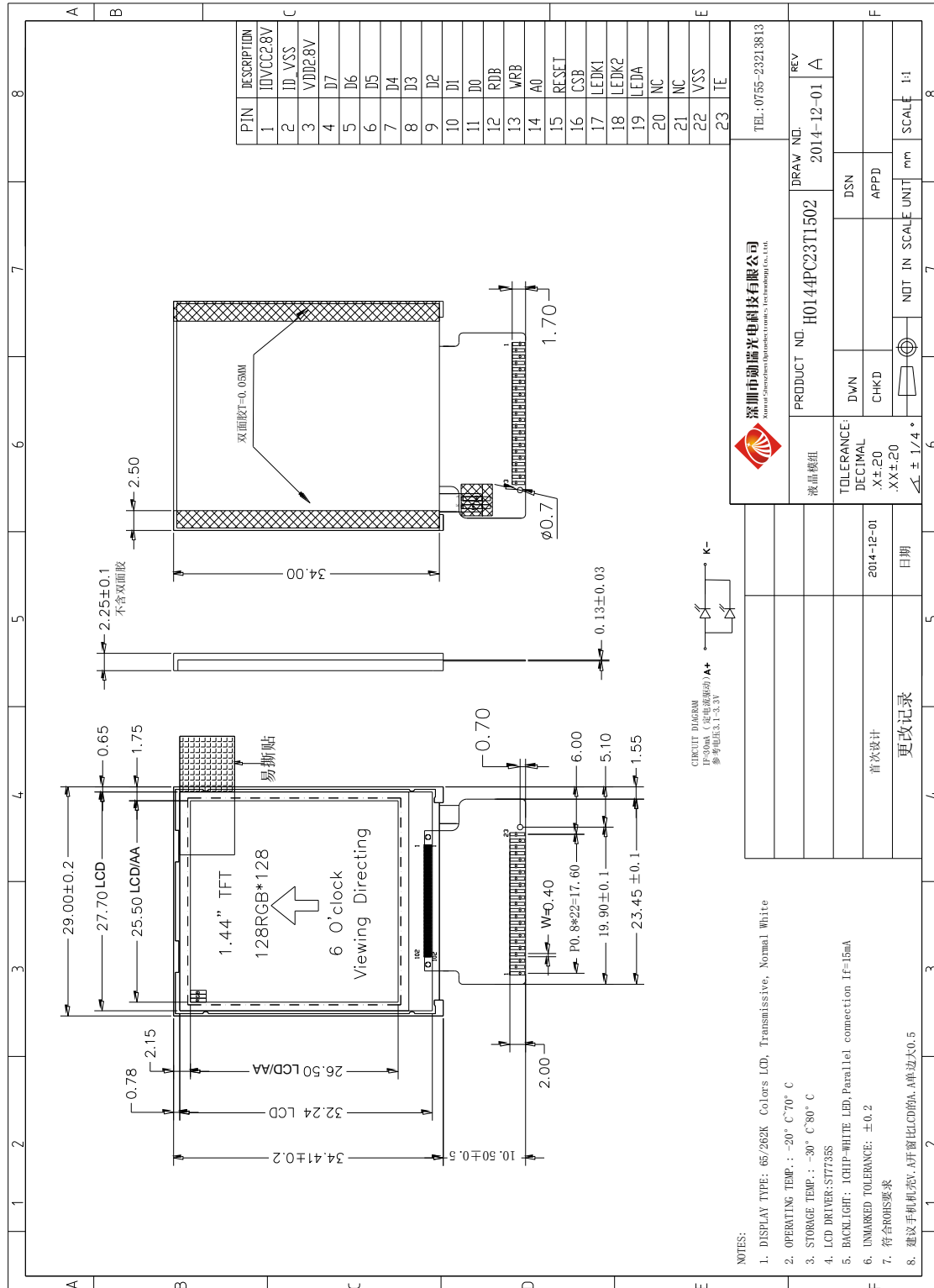



深圳市勋瑞光电科技有限公司
Xunrui Shenzhen Optoelectronics Technology Co., Ltd.

1 0.Packing

TBD



11. Precautions for Use of LCD modules

11.1 Handling Precautions

11.1.1. The display panel is made of glass. Do not subject it to a mechanical shock by dropping it from a high place, etc.

11.1.2. If the display panel is damaged and the liquid crystal substance inside it leaks out, be sure not to get any in your mouth, if the substance comes into contact with your skin or clothes, promptly wash it off using soap and water.

11.1.3. Do not apply excessive force to the display surface or the adjoining areas since this may cause the color tone to vary.

11.1.4. The polarizer covering the display surface of the LCD module is soft and easily scratched. Handle this polarizer carefully.

11.1.5. If the display surface is contaminated, breathe on the surface and gently wipe it with a soft dry cloth. If still not completely clear, moisten cloth with one of the following solvents:

- Isopropyl alcohol
- Ethyl alcohol

Solvents other than those mentioned above may damage the polarizer. Especially, do not use the following:
Water ; Ketene ; Aromatic solvents

11.1.6. Do not attempt to disassemble the LCD Module.

11.1.7. If the logic circuit power is off, do not apply the input signals.

11.1.8. To prevent destruction of the elements by static electricity, be careful to maintain an optimum work environment.

11.1.8.1. Be sure to ground the body when handling the LCD Modules.

11.1.8.2. Tools required for assembly, such as soldering irons, must be properly ground.

11.1.8.3. To reduce the amount of static electricity generated, do not conduct assembly and other work under dry conditions.

11.1.8.4. The LCD Module is coated with a film to protect the display surface. Be care when peeling off this protective film since static electricity may be generated.

11.2 Storage Precautions

11.2.1. When storing the LCD modules, avoid exposure to direct sunlight or to the light of fluorescent lamps.

11.2.2. The LCD modules should be stored under the storage temperature range. If the LCD modules will be stored for a long time, the recommend condition is:

Temperature : 0℃ ~ 40℃ Relatively humidity: ≤80%

11.2.3. The LCD modules should be stored in the room without acid, alkali and harmful gas.

11.3 Transportation Precautions

The LCD modules should be no falling and violent shocking during transportation, and also should avoid excessive press, water, damp and sunshine.