



深圳市勋瑞光电科技有限公司

Xunrui photoelectric technology (shenzhen) CO.,LTD.

Product Specification

Customer	Standard Module
Model Name	H043PWQ40E1K355
Description	TFT LCD Module 4.3"WQGA 480(RGB)x272 Dots
Date	2018/06/05
Version	1.0

Customer Approval

Date	
-------------	--

The above signature represents that the product specifications, testing regulation, and warranty in the specifications are accepted

Engineering

Check	Date	Prepared	Date



Table of Contents

1. Record of Revision.....	3
2 General Specifications.....	4
3 Input/Output Terminals.....	5
4.Absolute Maximum Ratings.....	6
5. Electrical Characteristics.....	6
6 Interface Timing.....	8
7 Optical Characteristics.....	13
8 Environmental / Reliability Tests.....	16
9 Mechanical Drawing.....	17
10 Packing.....	18
11 Precautions For Use of LCD modules.....	19



深圳市勋瑞光电科技有限公司

Xunrui Shenzhen Optoelectronics Technology Co., Ltd.

2 General Specifications

	Feature	Spec
Characteristics	Size	4.3inch
	Resolution	480(horizontal)*272(Vertical)
	Class Maker	CPT
	Interface	24bit- RGB
	Connect type	Connector
	Color Depth	16.7M
	Technology type	a-Si
	Display Spec.	0.198 x 0.198
	Pixel Configuration	R.G.B. Vertical Stripe
	Display Mode	Normally White
	Driver IC	ST7282G4
	Luminance	350 nits
	Viewing Direction	12:00 O'clock
	Gray Scale Inversion Direction	6:00 O'clock
Mechanical	LCM (W x H x D) (mm)	104.8*64.1*3
	Active Area(mm)	95.04 x 53.856
	With /Without TSP	Without
	Weight (g)	TBD
	LED Numbers	16 LEDs

Note 1: Viewing direction is follow the data which measured by optics equipment..

Note 2: Requirements on Environmental Protection: RoHS

Note 3: LCM weight tolerance: +/- 5%



3 Input/Output Terminals

No.	Symbol	Description
1	VBL-	Backlight LED Cathode
2	VBL+	Backlight LED Anode.
3	GND	System Ground
4	VCC	Power supply for logic operation
5~12	R0~R7	Data bus
13~20	G0~G7	Data bus
21~28	B0~B7	Data bus
29	GND	System Ground
30	CLK	Pixel clock signal
31	DISP	Display on/off control
32	HSYNC	Horizontal Sync signal
33	VSYNC	Vrtical Sync signal
34	DEN	Data Enable
35	NC	No connect
36	GND	System Ground
37	XR	TP pin XR
38	NC/YD	TP pin YD
39	NC/XL	TP pin XL
40	NC/YU	TP pin YU



4 Absolute Maximum Ratings

Item	Symbol	MIN	MAX	Unit	Remark
Supply Voltage	V _{DD}	-0.3	4.5	V	
Operating Temperature	T _{OPR}	-20	70	°C	
Storage Temperature	T _{STG}	-30	80	°C	

5 Electrical Characteristics

5.1 Driving TFT LCD Panel

T_a = 25 °C

Item	Symbol	MIN	TYP	MAX	Unit	Remark
Supply Voltage	V _{DD}	3.0	3.3	3.6	V	
Input Signal Voltage	Low Level	V _{IL}	GND	-	0.3x VDD	V
	High Level	V _{IH}	0.7x VDD	-	VDD	V
Output Signal Voltage	Low Level	V _{IL}	-	-	0.2x VDD	V
	High Level	V _{IH}	0.8x VDD	-	VDD	V
(Panel+LSI) Power Consumption	Black Mode (60Hz)	-	74		nW	
	Standby	-	50	-	uW	

5.2 Driving Backlight

Item	Symbol	MIN	TYP	MAX	Unit	Remark
Forward Current	I _F	-	20	25	mA	
Forward Voltage	V _F	-	22.4	23.1	V	
Backlight Power consumption	W _{BL}	-	0.448	0.525	W	
LED Lifetime		25000			Hrs	

Note 1: Each LED : I_F =20 mA, V_F =3.2V.

Note 2: Optical performance should be evaluated at T_a=25°C only.

Note 3: If LED is driven by high current, high ambient temperature & humidity condition. The life time of LED will be reduced. Operating life means brightness goes down to 50% initial brightness. Typical operating life time is estimated data.



Figure: LED connection of backlight



5.3 Block Diagram

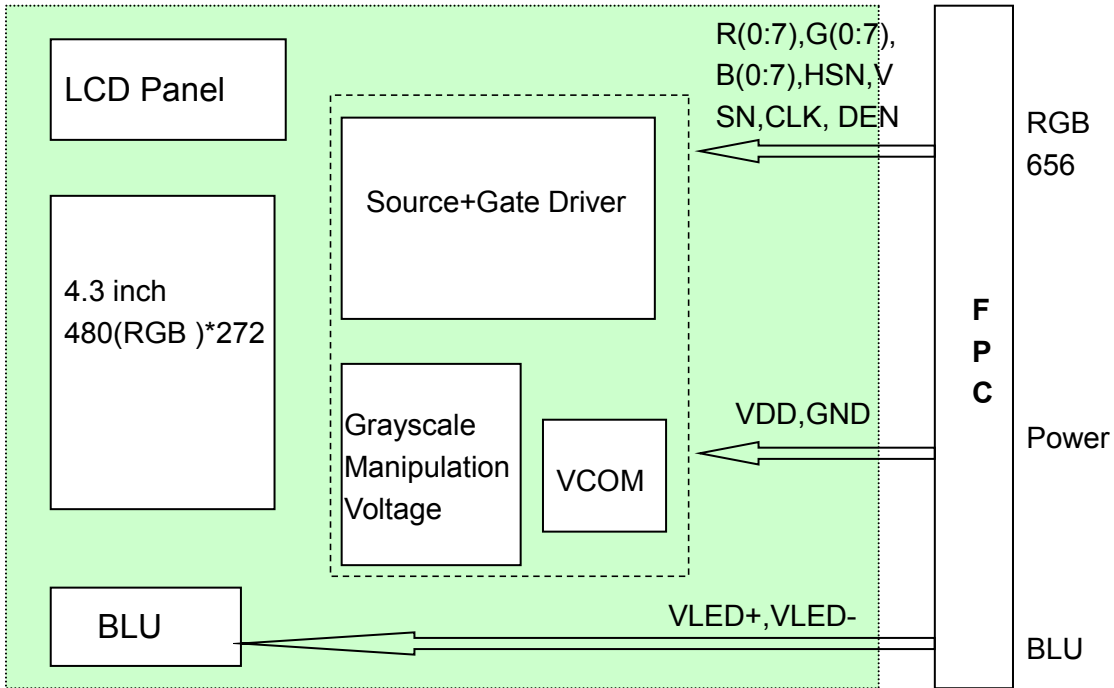



6 Interface Timing

6.1.1 Parallel RGB Data Format

Item	Symbol	Min.	Typ.	Max.	Unit	Remark
DCLK Frequency	Fclk	8	9	12	MHz	
DCLK Period	Tclk	83	111	125	ns	
HSYNC	Period Time	Th	485	531	DCLK	
	Display Period	Thdisp		480	DCLK	
	Back Porch	Thbp	3	43	DCLK	By H_Blanking setting
	Front Porch	Thfp	2	8	DCLK	
	Pulse Width	Thw	2	4	DCLK	
VSYNC	Period Time	Tv	276	292	H	
	Display Period	Tvdisp		272	H	
	Back Porch	Tvbp	2	12	H	By V_Blanking setting
	Front Porch	Tvfp	2	8	H	
	Pulse Width	Tvw	2	4	H	

Note: It is necessary to keep Tvbp =12 and Thbp =43 in sync mode. DE mode is unnecessary to keep it.

6.1.2 SYNC Mode Timing Diagram

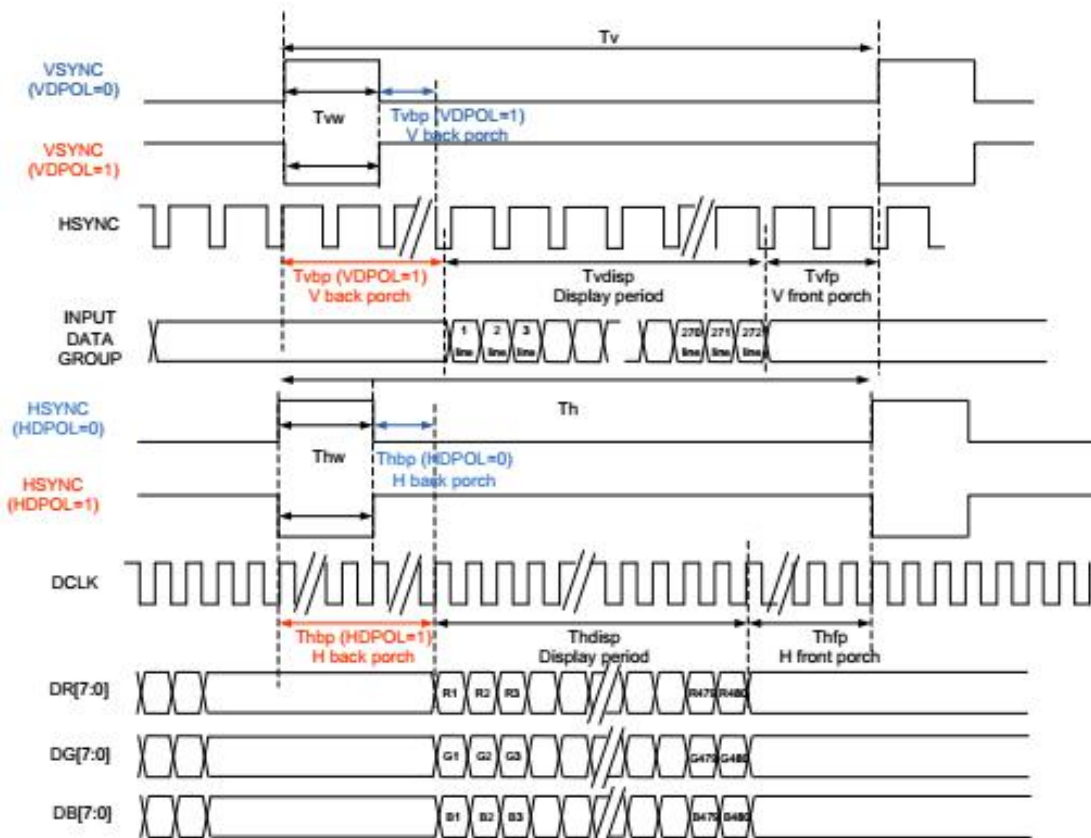



6.1.3 SYNC-DE Mode Timing Diagram

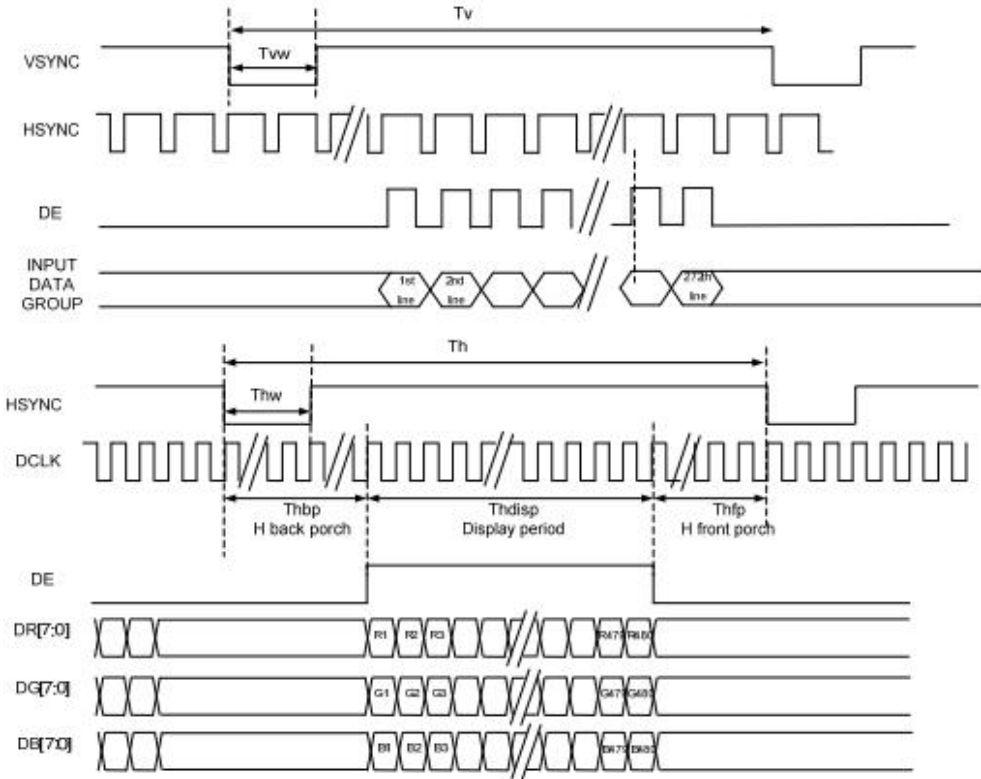

6.2 DE Mode Timing Diagram

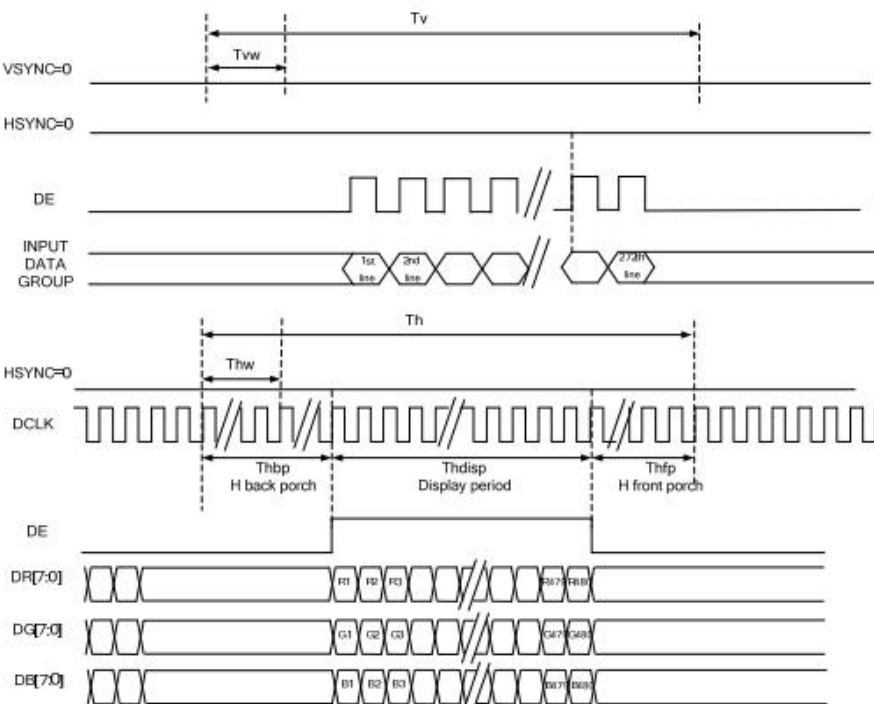



6.3 Power ON/OFF Sequence

6.3.1 Power ON Sequence

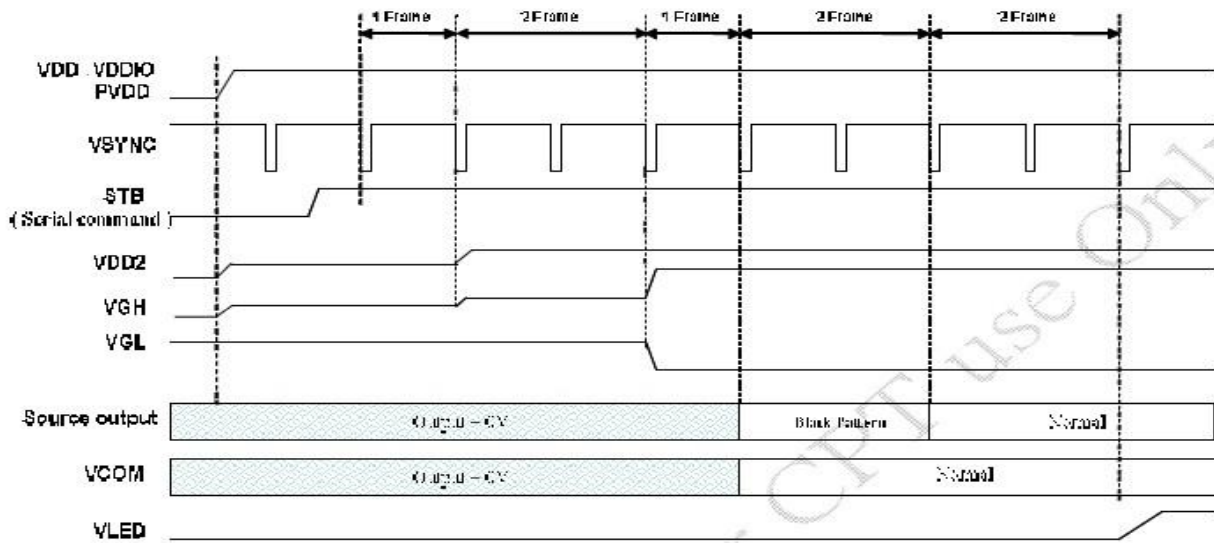

6.3.2 Power OFF Sequence

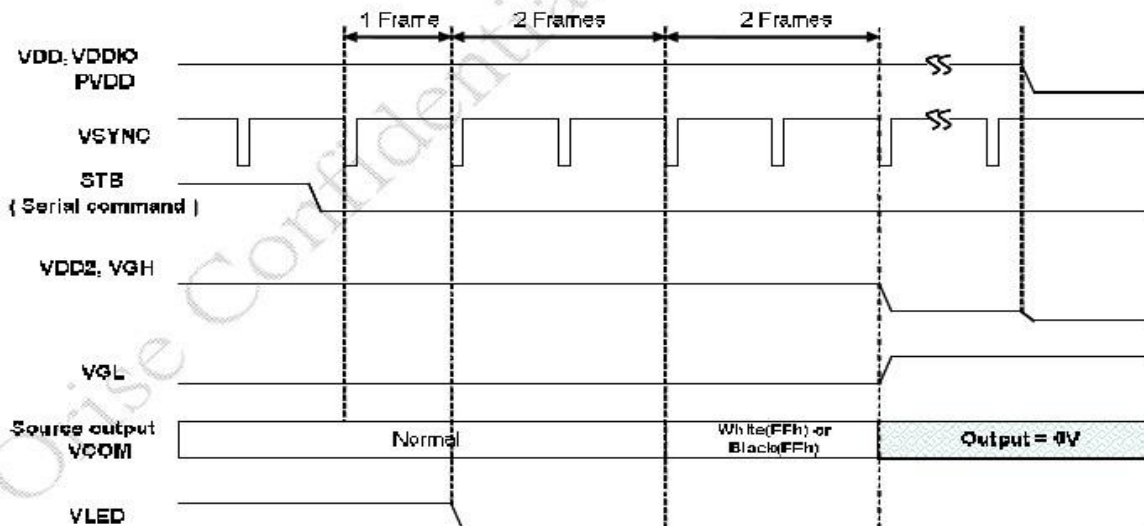



7 Optical Characteristics

Items	Symbol	Condition	Min.	Typ.	Max.	Unit	Remark	
Viewing angles	θ_T	Center CR \geq 10	-	60	-	Degree.	Note2	
	θ_B		-	70	-			
	θ_L		-	70	-			
	θ_R		-	70	-			
Contrast Ratio	CR	$\Theta = 0$	250	350		-	Note1, Note3	
Response Time	T _{ON}	25° C	-	30	45	ms	Note1, Note4	
	T _{OFF}		-	30	45			
Chromaticity	White	Backlight is on	X _W	0.282	0.312	0.342	-	Note1, Note5
			Y _W	0.319	0.349	0.379	-	
	Red		X _R	0.609	0.639	0.669	-	
			Y _R	0.314	0.344	0.374	-	
	Green		X _G	0.264	0.294	0.324	-	
			Y _G	0.557	0.587	0.617	-	
	Blue		X _B	0.102	0.132	0.162	-	
			Y _B	0.106	0.136	0.166	-	
Uniformity	U		75	80	-	%	Note1, Note6	
NTSC				50		%	Note5	
Luminance	L		-	1300			Note1, Note7	

Test Conditions:

1. IF= 20mA(one channel),the ambient temperature is 25.
2. The test systems refer to Note 1 and Note 2.

Note 1: Definition of optical measurement system.

The optical characteristics should be measured in dark room. After 5 minutes operation, the optical properties are measured at the center point of the LCD screen. All input terminals LCD panel must be ground when measuring the center area of the panel.



深圳市勋瑞光电科技有限公司

Xunrui Shenzhen Optoelectronics Technology Co., Ltd.

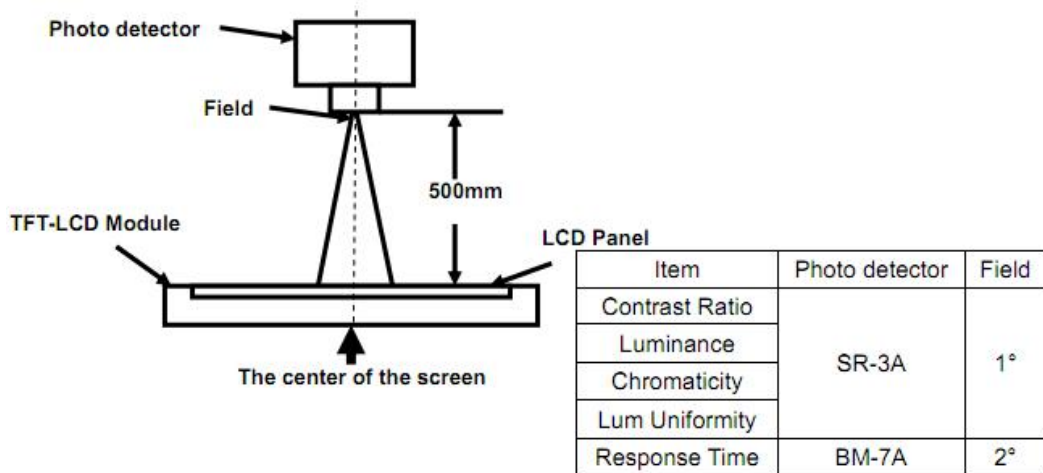

Note 2: Definition of viewing angle range and measurement system.

viewing angle is measured at the center point of the LCD by CONOSCOPE(ergo-80).

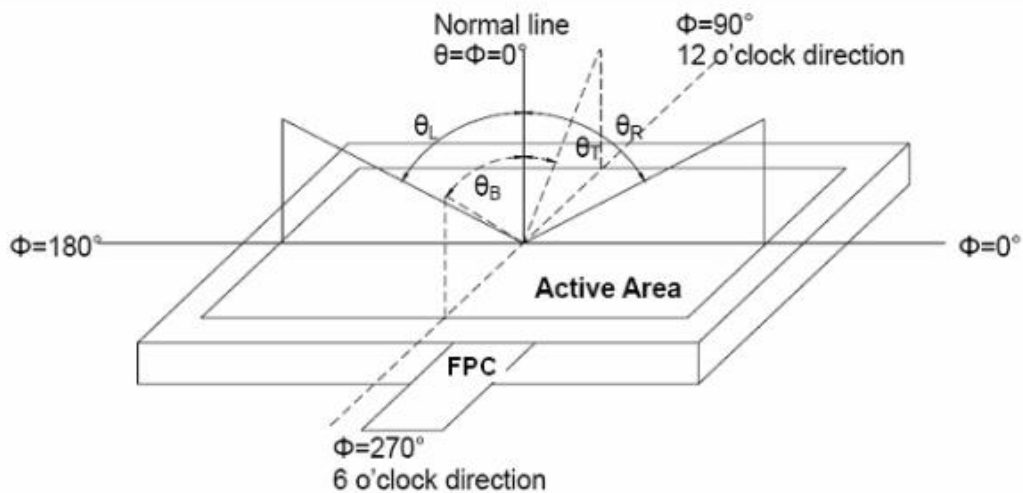

Fig. 1 Definition of viewing angle

Note 3: Definition of contrast ratio

$$\text{Contrast ratio (CR)} = \frac{\text{Luminance measured when LCD is on the "White" state}}{\text{Luminance measured when LCD is on the "Black" state}}$$

Note 4: Definition of Response time

The response time is defined as the LCD optical switching time interval between "White" state and "Black" state. Rise time (TON) is the time between photo detector output intensity changed from 90% to 10%. And fall time (TOFF) is the time between photo detector output intensity changed from 10% to 90%.

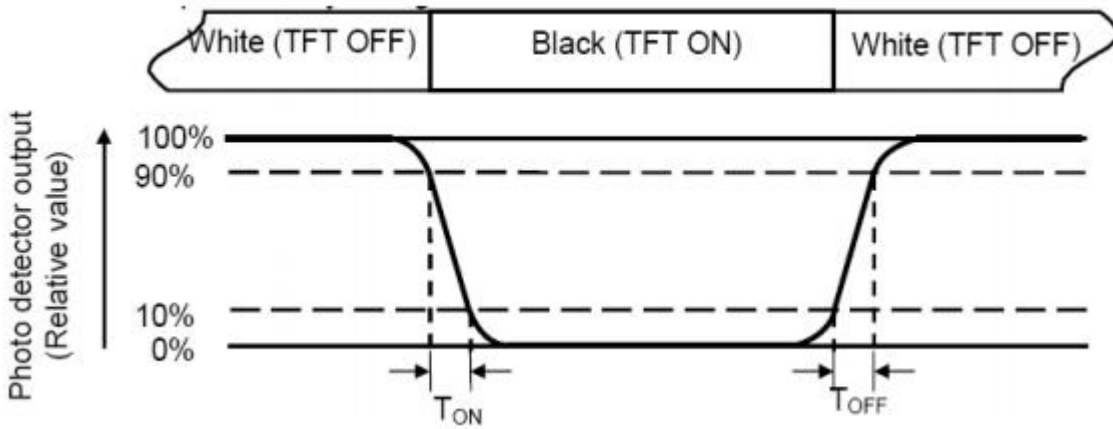

Note 5: Definition of color chromaticity (CIE1931)

Color coordinates measured at center point of LCD.

Note 6: Definition of Luminance Uniformity

Active area is divided into 9 measuring areas (Refer Fig. 2). Every measuring point is placed at the center of each measuring area.

$$\text{Luminance Uniformity}(U) = L_{\min} / L_{\max} \times 100\%$$

L-----Active area length W----- Active area width

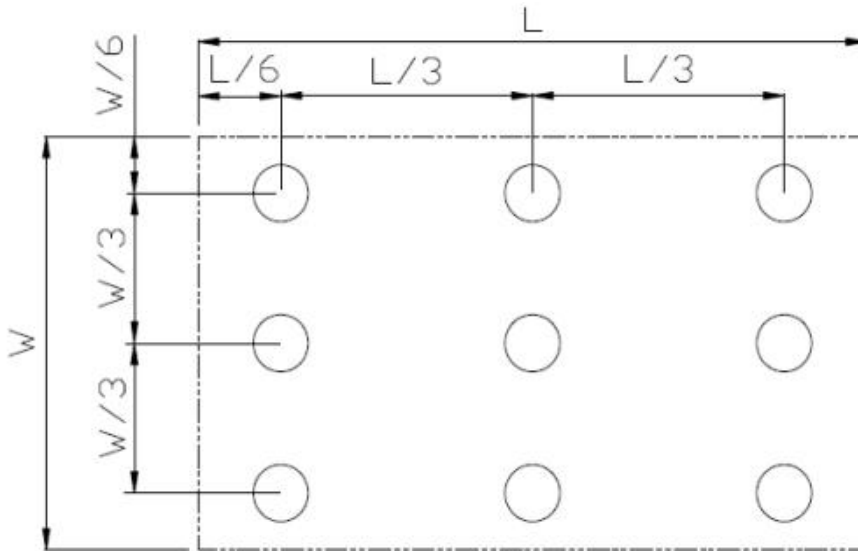

Fig. 2 Definition of uniformity

L_{\max} : The measured maximum luminance of all measurement position.

L_{\min} : The measured minimum luminance of all measurement position.

Note 7: Definition of Luminance :

Measure the luminance of white state at center point.



8 Environmental Tests

No	Test Item	Condition	Remarks
1	High Temperature Opeartion	Ts= +70℃, 240hrs	Note 1 IEC60068-2-2, GB2423. 2-89
2	Low Temperature Opeartion	Ta= -20℃, 240hrs	Note 2 IEC60068-2-1 GB2423.1-89
3	High Temperature Storage	Ta= +80℃, 240hrs	IEC60068-2-2 GB2423. 2-89
4	Low Temperature Storage	Ta= -30℃, 240hrs	IEC60068-2-1 GB/T2423.1-89
5	High Temperature & Humidity Storage	Ta= +60℃, 90% RH max, 160 hours	IEC60068-2-3 GB/T2423.3-2006
6	Thermal Shock (Non-operation)	-30℃ 30 min ~ +80℃ 30 min Change time: 5min, 30 Cycle	Start with cold temperature,end with high temperature IEC60068-2-14, GB2423.22-87
7	Electro Static Discharge (Opeartion)	C=150pF, R=330 Ω, 5 points/panel Air: ±8KV, 5 times; Contact: ±4KV, 5 times; (Environment: 15℃ ~ 35℃, 30% ~ 60%, 86Kpa ~ 106Kpa)	IEC61000-4-2 GB/T17626.2-1998
8	Vibration (Non-operation)	Frequency range: 10~55Hz, Stroke: 1.mm Sweep: 10Hz~55Hz~10Hz 2 hours for each direction of X .Y. Z. (package condition)	IEC60068-2-6 GB/T2423.5-1995
9	Shock (Non-operation)	60G 6ms, ± X, ± Y , ± Z 3 times for each direction	IEC60068-2-27 GB/T2423.5-1995
10	Package Drop Test	Height: 80 cm, 1 corner, 3 edges, 6 surfaces	IEC60068-2-32 GB/T2423.8-1995

Note: 1. Ts is the temperature of panel's surface.
2. Ta is the ambient temperature of sample.



9 Mechanical Drawing

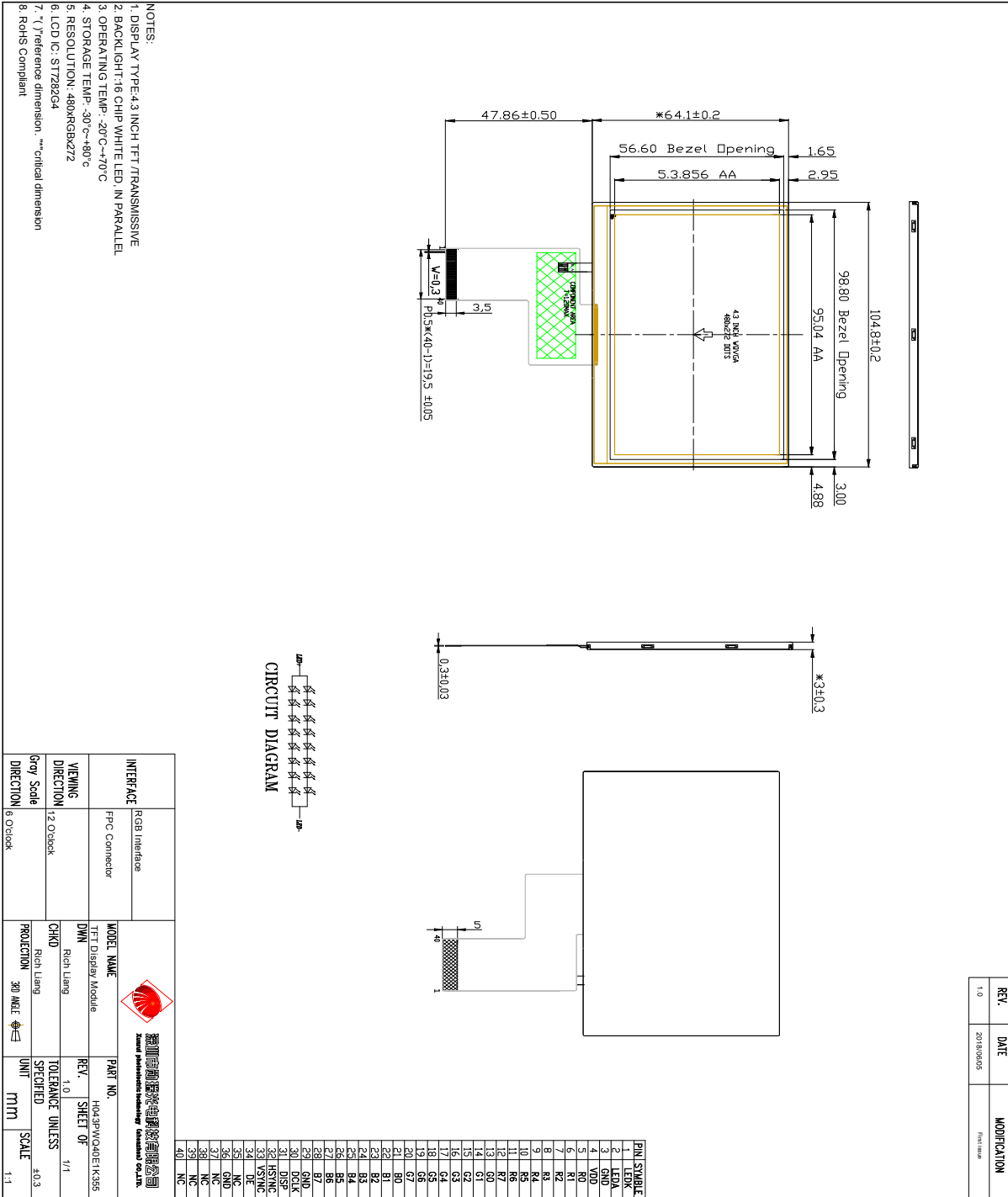



10 Packing

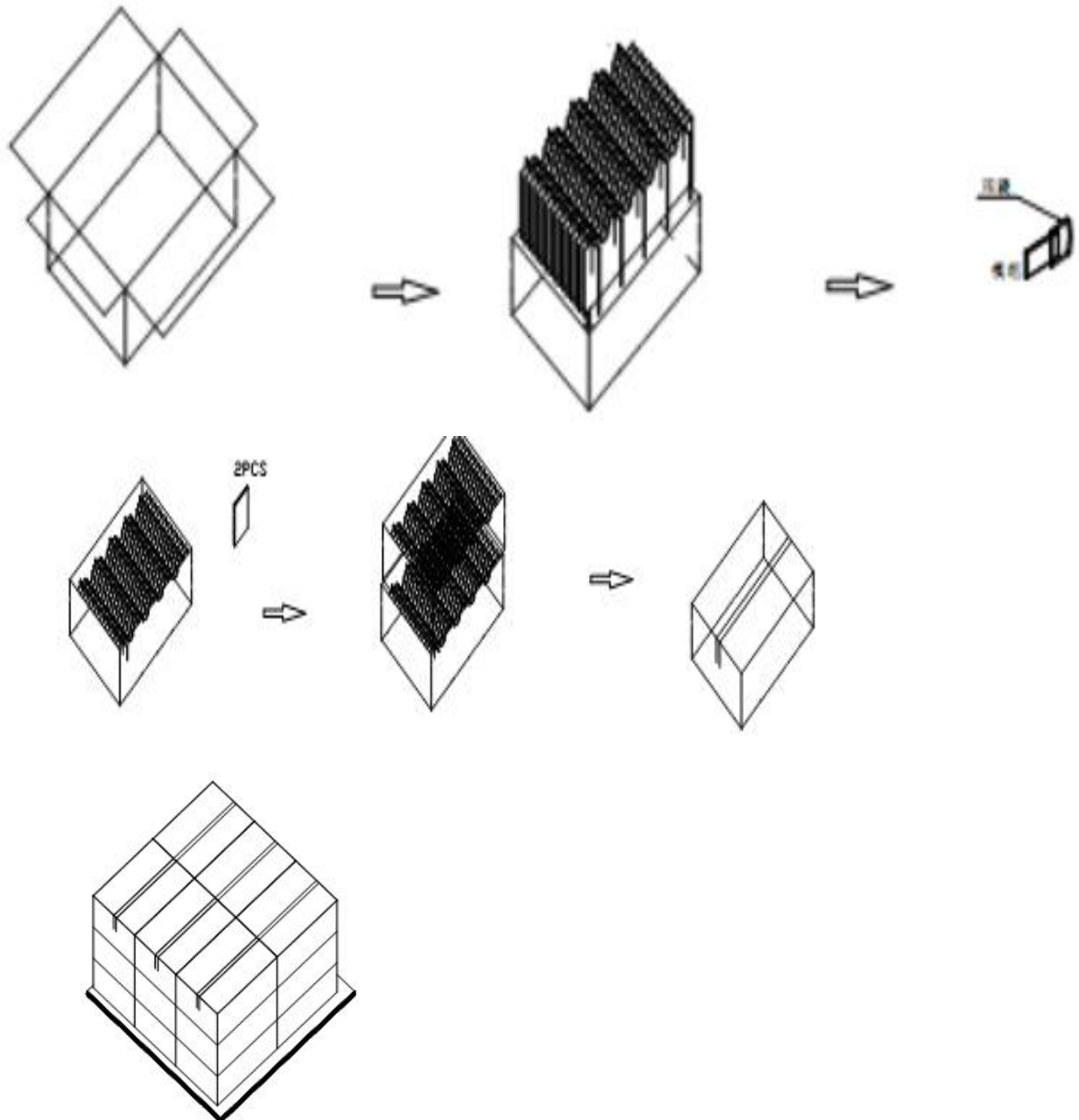



11 Precautions for Use of LCD modules

11.1 Handling Precautions

11.1.1. The display panel is made of glass. Do not subject it to a mechanical shock by dropping it from a high place, etc.

11.1.2. If the display panel is damaged and the liquid crystal substance inside it leaks out, be sure not to get any in your mouth, if the substance comes into contact with your skin or clothes, promptly wash it off using soap and water.

11.1.3. Do not apply excessive force to the display surface or the adjoining areas since this may cause the color tone to vary.

11.1.4. The polarizer covering the display surface of the LCD module is soft and easily scratched. Handle this polarizer carefully.

11.1.5. If the display surface is contaminated, breathe on the surface and gently wipe it with a soft dry cloth. If still not completely clear, moisten cloth with one of the following solvents:

- Isopropyl alcohol
- Ethyl alcohol

Solvents other than those mentioned above may damage the polarizer. Especially, do not use the following:

- Water
- Ketene
- Aromatic solvents

11.1.6. Do not attempt to disassemble the LCD Module.

11.1.7. If the logic circuit power is off, do not apply the input signals.

11.1.8. To prevent destruction of the elements by static electricity, be careful to maintain an optimum work environment.

11.1.8.1. Be sure to ground the body when handling the LCD Modules.

11.1.8.2. Tools required for assembly, such as soldering irons, must be properly ground.

11.1.8.3. To reduce the amount of static electricity generated, do not conduct assembly and other work under dry conditions.

11.1.8.4. The LCD Module is coated with a film to protect the display surface. Be care when peeling off this protective film since static electricity may be generated.

11.2 Storage Precautions

11.2.1. When storing the LCD modules, avoid exposure to direct sunlight or to the light of fluorescent lamps.

11.2.2. The LCD modules should be stored under the storage temperature range. If the LCD modules will be stored for a long time, the recommend condition is:

Temperature : 0℃ ~ 40℃ Relatively humidity: ≤80%

11.2.3. The LCD modules should be stored in the room without acid, alkali and harmful gas.

11.3 Transportation Precautions

The LCD modules should be no falling and violent shocking during transportation, and also should avoid excessive press, water, damp and sunshine.